

2017 national curriculum tests

Key stage 2

Mathematics

Paper 3: reasoning

First name						
Middle name						
Last name						
Date of birth	Day		Month		Year	
School name						
DfE number						



[BLANK PAGE]

Please do not write on this page.



Instructions

You **must not** use a calculator to answer any questions in this test.

Questions and answers

You have **40 minutes** to complete this test.

Follow the instructions for each question.

Work as quickly and as carefully as you can.

If you need to do working out, you can use the space around the question.

Do not write over any barcodes.

Some questions have a method box like this:

Diagram illustrating a method box. A rounded rectangle on the left contains the text "Show your method". This is connected to a large grid of red lines. In the bottom right corner of the grid, there is a smaller, empty rectangular box.

For these questions, you may get a mark for showing your method.

If you cannot do a question, **go on to the next one**.

You can come back to it later, if you have time.

If you finish before the end, **go back and check your work**.

Marks

The number under each line at the side of the page tells you the maximum number of marks for each question.



1

Write the missing number to make this **division** correct.

$$75 \div \boxed{} = 7.5$$

1 mark

2

A group of friends earns £80 by washing cars.

They share the money **equally**.

They get £16 each.

How many friends are in the group?

1 mark



3

Chen uses these digit cards.

5

6

9

She makes a 2-digit number and a 1-digit number.

She multiplies them together.

Her answer is a **multiple of 10**

What could Chen's multiplication be?

$$\begin{array}{|c|c|} \hline & \\ \hline \end{array} \times \begin{array}{|c|} \hline \\ \hline \end{array}$$

1 mark



F 0 0 0 8 0 A 0 5 2 4

4

This graph shows the temperature in °C from 2 am to 3 pm on a cold day.

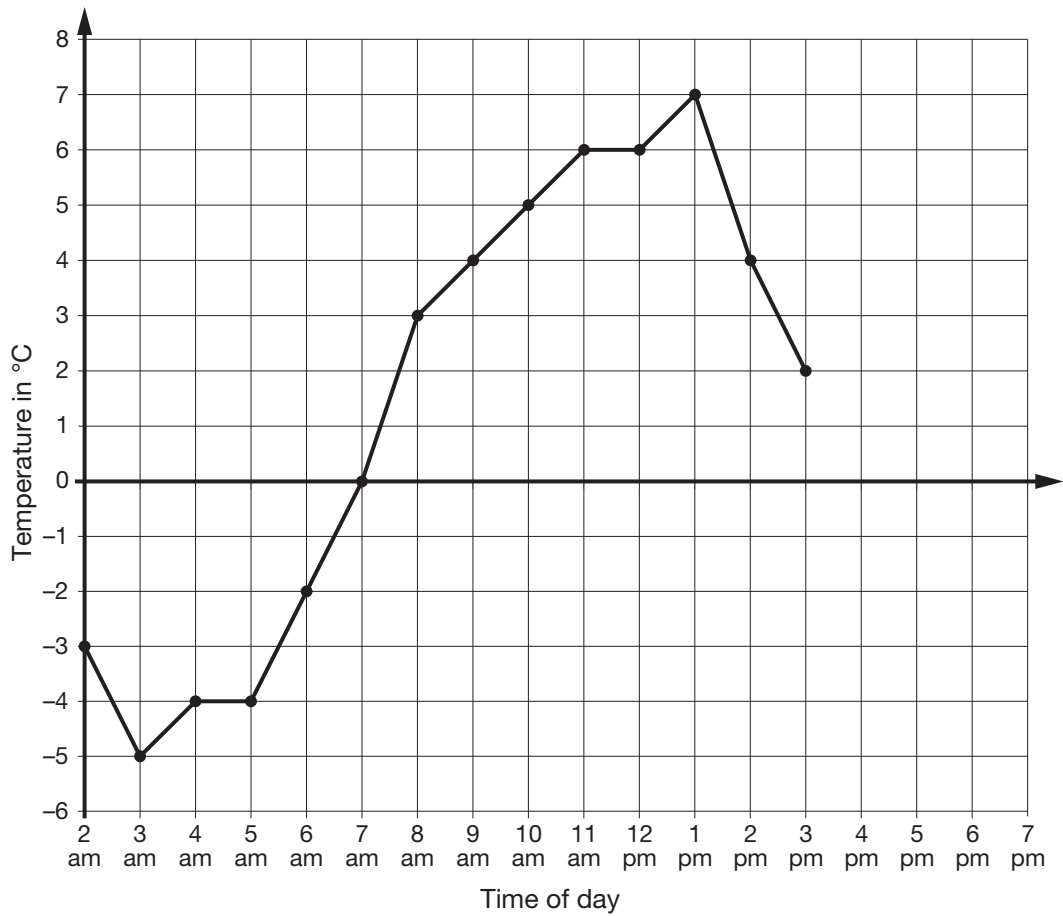

How many degrees **warmer** was it at 3 pm than at 3 am?

°C

1 mark

At 6 pm the temperature was 4 degrees lower than at 3 pm.

What was the temperature at 6 pm?

°C

1 mark



5

The children at Farmfield School are collecting money for charity.

Their target is to collect £360

So far they have collected £57.73

How much **more** money do they need to reach their target?

£

1 mark



F 0 0 0 8 0 A 0 7 2 4

6

William wants to travel to Paris by train.

He needs to arrive in Paris by **5:30 pm**.

Circle the **latest time** that William can leave London.

Leaves London	Arrives Paris
12:01	15:22
12:25	15:56
13:31	16:53
14:01	17:26
14:31	17:53
15:31	18:53
16:01	19:20

1 mark



7

Here is a triangle drawn on a coordinate grid.

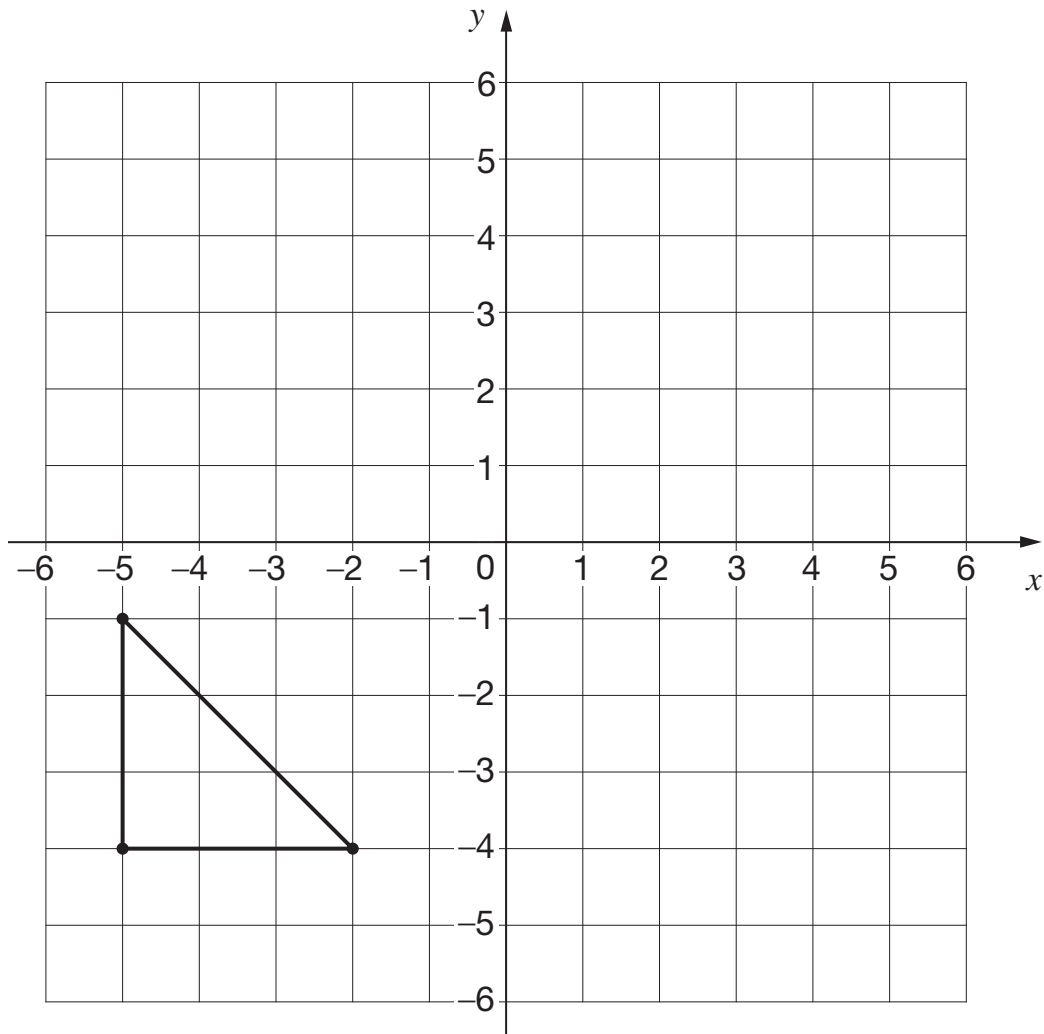

1 mark

The triangle is translated **7 right** and **5 up**.

Draw the triangle in its new position.



F 0 0 0 8 0 A 0 9 2 4

8

Write three factors of 30 that are **not** factors of 15

--	--	--

2 marks

9

Here is the morning timetable for Chen's class this week.

Time	Mon	Tue	Wed	Thu	Fri
9:00 am–10:30 am	Maths	English	Maths	English	Maths
10:30 am–11:00 am	Break	Break	Break	Break	Break
11:00 am–12:00 pm	English	Maths	Science	Maths	English

What is the **total** number of hours for **English** on this timetable?

hours

1 mark



10

A bottle contains 568 millilitres of milk.

Jack pours out **half a litre**.



How much milk is left?

1 mark

11

A bicycle wheel has a diameter of 64 cm.

What is the **radius** of the bicycle wheel?

1 mark



12



Adam buys **6** bags of white balloons.

Chen buys **3** bags of red balloons.

Adam says,

'I have four times as many balloons as Chen.'

Explain why Adam is correct.

1 mark



13

Circle the pentagon with exactly four acute angles.

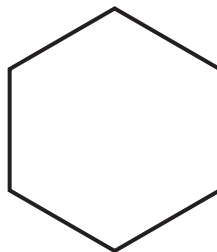
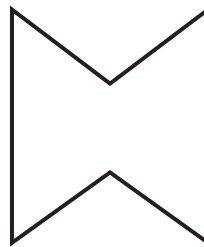
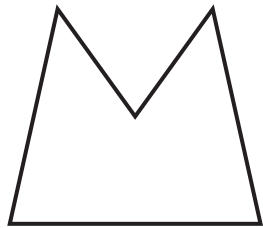
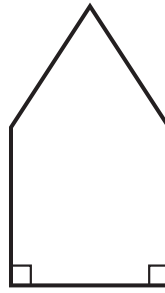
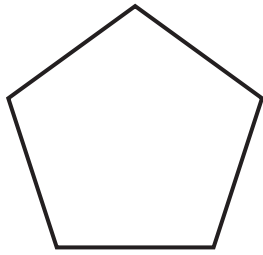

1 mark



15

Look at the letters below.

Circle the letter below that has both parallel **and** perpendicular lines.

A C E L Z

1 mark



F 0 0 0 8 0 A 0 1 5 2 4

16

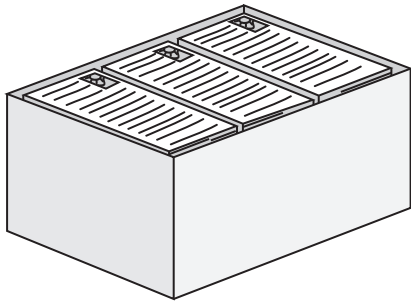

There are 2,400 leaflets in a box.

William and Ally take 450 leaflets each.

Adam and Chen share the rest of the leaflets equally.

How many leaflets does Adam get?

Show your method

2 marks



17

In each box, circle the number that is **greater**.

$1\frac{1}{2}$

1.2

$1\frac{1}{4}$

1.3

$1\frac{5}{100}$

1.4

$1\frac{3}{5}$

1.5

2 marks



F 0 0 0 8 0 A 0 1 7 2 4

18

A **square** number and a **prime** number have a total of 22

What are the two numbers?

$$\begin{array}{ccc} \boxed{} & + & \boxed{} = 22 \\ \text{square} & & \text{prime} \\ \text{number} & & \text{number} \end{array}$$

1 mark

19

Dev thinks of a **whole** number.

He multiplies it by 4

He rounds his answer to the nearest 10

The result is 50

Write **all** the possible numbers that Dev could have started with.

2 marks



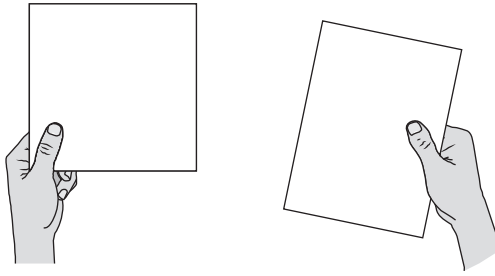

A square tile measures 20 cm by 20 cm.

A rectangular tile is 3 cm **longer** and 2 cm **narrower** than the square tile.

What is the **difference in area** between the two tiles?

Show
your
method

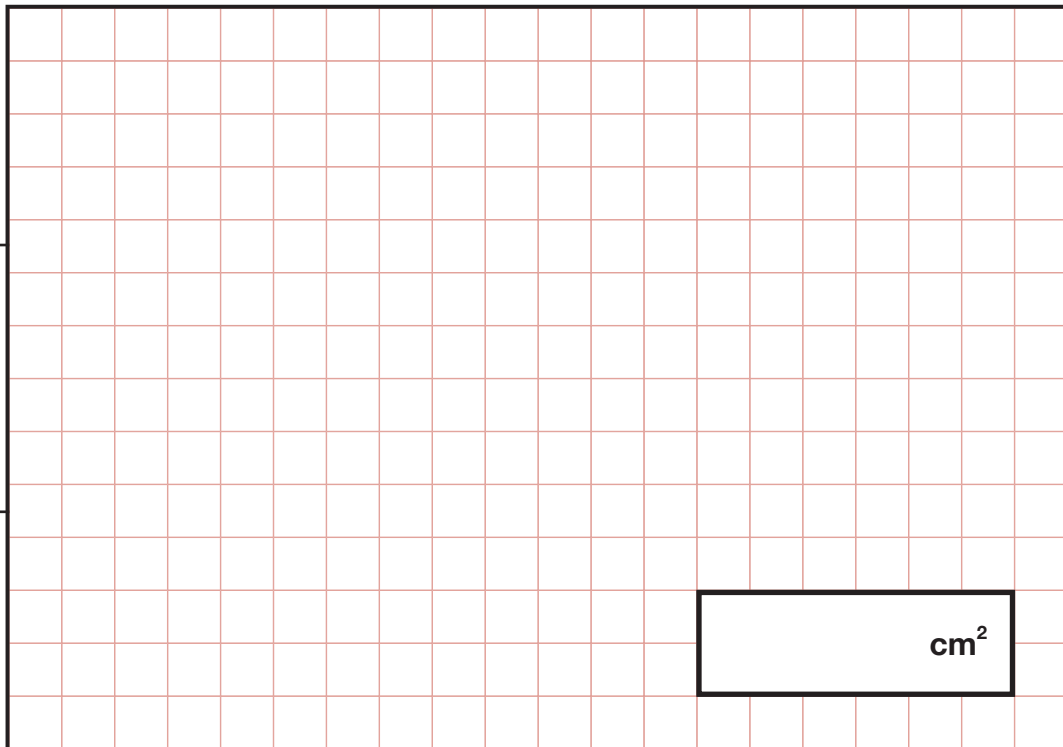

3 marks



21

The numbers in this sequence increase by the same amount each time.

Write the missing numbers.

1 mark

1 mark



22

In this diagram, the shaded rectangles are all of equal width (w).

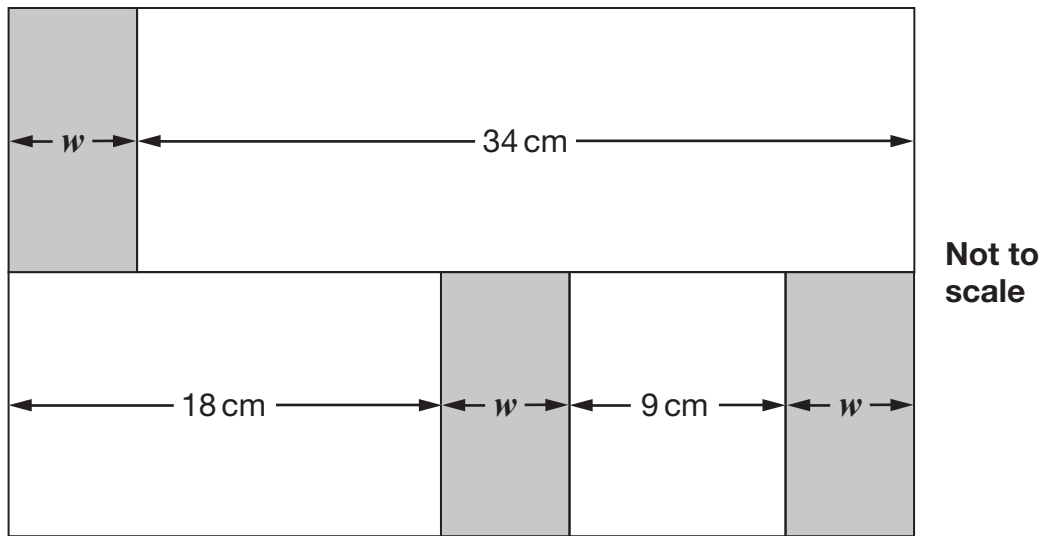

Calculate the width (w) of one shaded rectangle.

Show
your
method

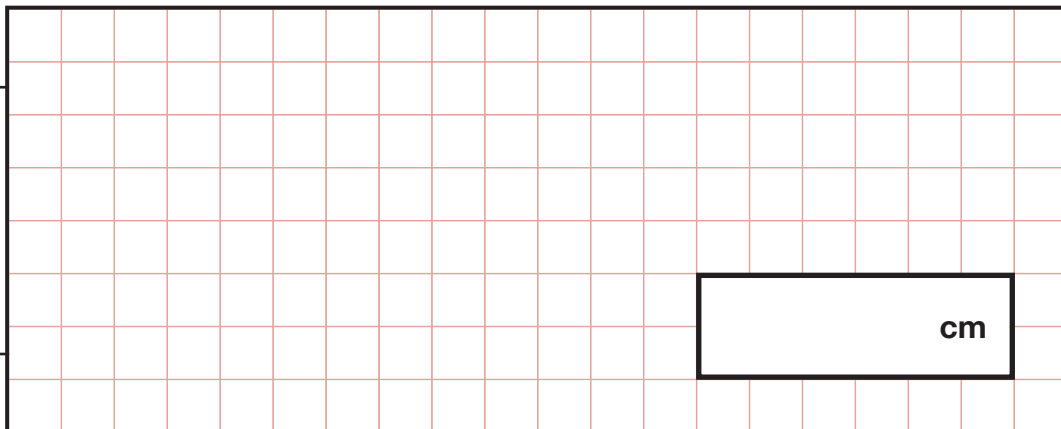

2 marks



F 0 0 0 8 0 A 0 2 1 2 4

23

Here is a pattern of number pairs.

a	b
1	9
2	19
3	29
4	39

Complete the **rule** for the number pattern.

$$b = \boxed{} \times a - \boxed{}$$

1 mark



24

Cube A and cuboid B have the same volume.

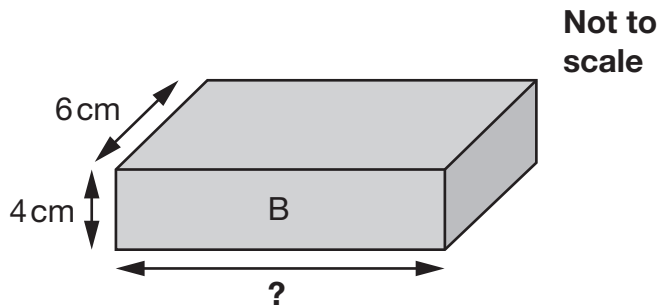
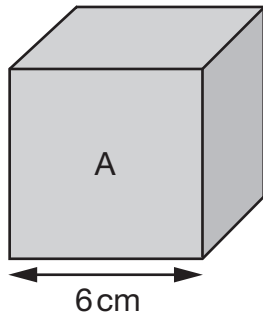

Calculate the missing length on cuboid B.

Show
your
method

A large grid for showing the method. A small rectangular box is drawn on the grid, containing the text 'cm'.

2 marks



F 0 0 0 8 0 A 0 2 3 2 4



2017 key stage 2 mathematics

Paper 3: reasoning

Print version product code: STA/17/7738/p ISBN: 978-1-78644-277-2

Electronic PDF version product code: STA/17/7738/e ISBN: 978-1-78644-297-0

For more copies

Additional printed copies of this booklet are not available. It can be downloaded from www.gov.uk/government/publications.

© Crown copyright and Crown information 2017

Re-use of Crown copyright and Crown information in test materials

Subject to the exceptions listed below, the test materials on this website are Crown copyright or Crown information and you may re-use them (not including logos) free of charge in any format or medium in accordance with the terms of the Open Government Licence v3.0 which can be found on the National Archives website and accessed via the following link: www.nationalarchives.gov.uk/doc/open-government-licence.

When you use this information under the Open Government Licence v3.0, you should include the following attribution: 'Contains public sector information licensed under the Open Government Licence v3.0' and where possible provide a link to the licence.



Exceptions – third-party copyright content in test materials

You must obtain permission from the relevant copyright owners, as listed in the '2017 key stage 2 tests copyright report', for re-use of any third-party copyright content which we have identified in the test materials, as listed below. Alternatively you should remove the unlicensed third-party copyright content and/or replace it with appropriately licensed material.

Third-party content

These materials contain no third-party copyright content.

If you have any queries regarding these test materials contact the national curriculum assessments helpline on 0300 303 3013 or email assessments@education.gov.uk.



F 0 0 0 8 0 A 0 2 4 2 4